

Vertical Clock Driver for CCD Image sensor

Description

CXD1250M/N is a clock driver developed for the vertical register drive of CCD Image sensor.

Features

4-channel vertical clock driver and 1 channel substrate driver are built-in.

Application

CCD camera

Structure

CMOS

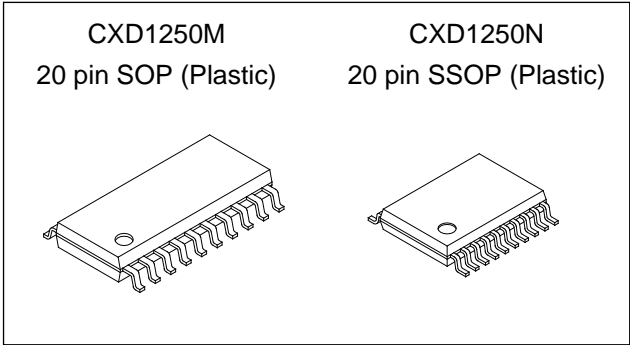

Absolute Maximum Ratings (Ta = 25°C)

• Supply voltage	V_{DD}	$V_L - 0.3$ to $V_L + 35.0$	V
	V_M	$V_L - 0.3$ to $V_L + 35.0$	V
	V_H	$V_L - 0.3$ to $V_L + 35.0$	V
	V_{HH}	$V_L - 0.3$ to $V_L + 35.0$	V
• Input voltage	V_i	$V_L - 0.3$ to $V_{DD} + 0.3$	V
• Output voltage	$MV\phi$ (pins 13, 17)	$V_L - 0.3$ to $V_M + 0.3$	V
• Output voltage	$HV\phi$ (pins 14, 16)	$V_L - 0.3$ to $V_H + 0.3$	V
• Output voltage	$HHV\phi$ (pin 19)	$V_L - 0.3$ to $V_{HH} + 0.3$	V
• Operating temperature	T_{opr}	-25 to +85	°C
• Storage temperature	T_{stg}	-40 to +125	°C

Recommended Operating Conditions

• Supply voltage	V_{DD}	5.0 ± 0.5	V
	V_M	$V_L + 10.0$	V
	V_H	$V_L + 25.0$	V
	V_{HH}	$V_L + 30.0$	V
	V_L	-10.0	V
• Operating temperature	T_{opr}	-20 to +75	°C

Sony reserves the right to change products and specifications without prior notice. This information does not convey any license by any implication or otherwise under any patents or other right. Application circuits shown, if any, are typical examples illustrating the operation of the devices. Sony cannot assume responsibility for any problems arising out of the use of these circuits.

Block Diagram and Pin Configuration (Top View)

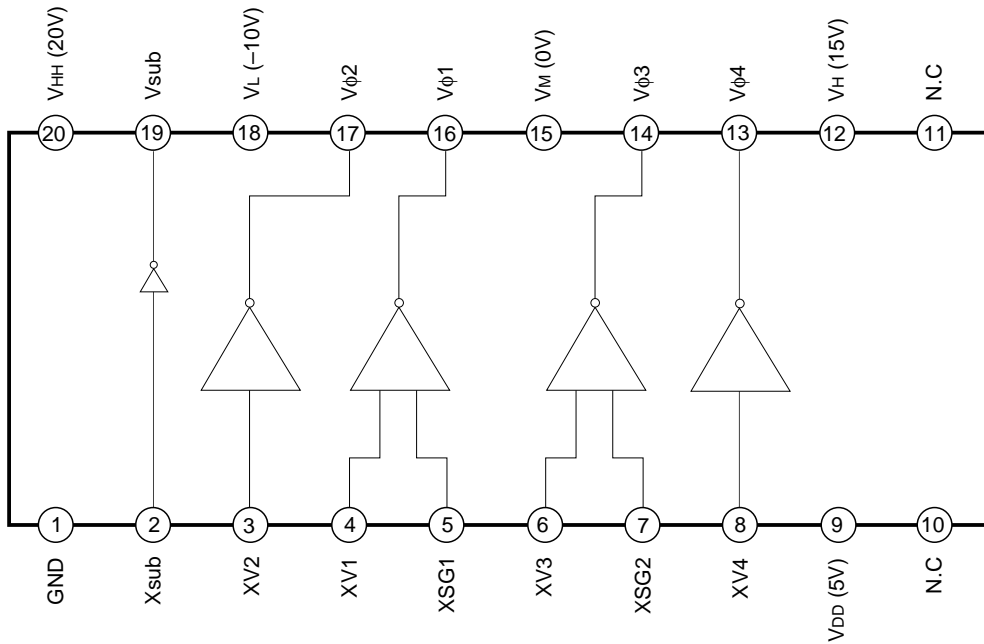

Pin Description

No.	Symbol	I/O	Description
1	GND	—	GND
2	Xsub	I	Output control (Vsub)
3	XV2	I	Output control (Vφ2)
4	XV1	I	Output control (Vφ1)
5	XSG1	I	Output control (Vφ1)
6	XV3	I	Output control (Vφ3)
7	XSG2	I	Output control (Vφ3)
8	XV4	I	Output control (Vφ4)
9	VDD	—	Power supply (5V)
10	NC	—	
11	NC	—	
12	VH	—	Power supply (15V)
13	Vφ4	O	Output (2 level : VM, VL)
14	Vφ3	O	Output (3 level : VH, VM, VL)
15	VM	—	Power supply (0V)
16	Vφ1	O	Output (3 level : VH, VM, VL)
17	Vφ2	O	Output (2 level : VM, VL)
18	VL	—	Power supply (-10V)
19	Vsub	O	Output (2 level : VHH, VL)
20	VHH	—	Power supply (20V)

Truth Table

Input				Output		
XV1 · 3	XSG1 · 2	XV2 · 4	Xsub	V ϕ 1 · 3	V ϕ 2 · 4	Vsub
L	H	X	X	V _M	X	X
H	H	X	X	V _L	X	X
X	X	L	X	X	V _M	X
X	X	H	X	X	V _L	X
X	X	X	L	X	X	V _{HH}
X	X	X	H	X	X	V _L
L	L	X	X	V _H	X	X
H	L	X	X	Z	X	X

X : Don't care
Z : High impedance

DC Characteristics (Ta = 25°C)

Item	Symbol	Test condition		Min.	Typ.	Max.	Unit
			Power supply				
"H" level input voltage	V _{IH}			3.5	—	—	V
"L" level input voltage	V _{IL}			—	—	1.5	V
"L" level output voltage	V ϕ _L	I ϕ _L = 20 μ A		—	-10	-9.9	V
"M" level output voltage	V ϕ _M	I ϕ _M = -20 μ A		—	0.0	0.1	V
"M" level output voltage	V ϕ _M	I ϕ _M = 20 μ A		-0.1	0.0	—	V
"H" level output voltage	V ϕ _H	I ϕ _H = -20 μ A		14.9	15	—	V
"HH" level output voltage	V ϕ _{HH}	I ϕ _{HH} = -20 μ A		19.9	20	—	V
Input current	I _i			—	1.0	—	μ A
Power supply current *	I _M			—	4.5	5.0	mA
Power supply current *	I _{DD}			—	0.3	0.5	mA
Power supply current *	I _H			—	0.1	0.2	mA
Power supply current *	I _{HH}			—	0.05	0.1	mA

* Supply current at operation (See the Test Circuit)

Switching Characteristics (See the Test Circuit $T_a = 25^\circ\text{C}$, $V_{HH} = 20\text{V}$, $V_H = 15\text{V}$, $V_M = 0\text{V}$, $V_L = -10\text{V}$, $V_{DD} = 5\text{V}$)

Item	Symbol	Conditions	Max.	Min.	Unit
Output current	I_L	$V_{\phi 1 \text{ to } 4} = -9.5\text{V}$	-25		mA
Output current	I_{M1}	$V_{\phi 1 \text{ to } 4} = -0.5\text{V}$		10	mA
Output current	I_{M2}	$V_{\phi 1, 3} = 0.5\text{V}$	-9		mA
Output current	I_H	$V_{\phi 1, 3} = 14.5\text{V}$		12	mA
Output current	I_{SL}	$V_{\text{sub}} = -9.5\text{V}$	-12		mA
Output current	I_{SH}	$V_{\text{sub}} = -19.5\text{V}$		7	mA
Rise time $V_L \rightarrow V_M$	T_{TLM}	$V_{\phi 1 \text{ to } 4} = -0.5\text{V}$ After input transient	1000		ns
Fall time $V_M \rightarrow V_L$	T_{TML}	$V_{\phi 1 \text{ to } 4} = -9.5\text{V}$ After input transient	500		ns
Rise time $V_M \rightarrow V_H$	T_{TMH}	$V_{\phi 1, 3} = 14\text{V}$ After input transient	1000		ns
Fall time $V_H \rightarrow V_M$	T_{THM}	$V_{\phi 1, 3} = 1\text{V}$ After input transient	1000		ns
Rise time $V_L \rightarrow V_{HH}$	T_{TLHH}	$V_{\text{sub}} = 17\text{V}$ After input transient	200		ns
Fall time $V_{HH} \rightarrow V_L$	T_{THHL}	$V_{\text{sub}} = -7\text{V}$ After input transient	200		ns
Coupling amplitude (middle level)	V_{COM}	$V_{\phi 1 \text{ to } 4}$	0.5		V
Coupling amplitude (low level)	V_{COL}	$V_{\phi 1 \text{ to } 4}$	0.5		V

Input Waveform (Repeat Cycle 15.7kHz)

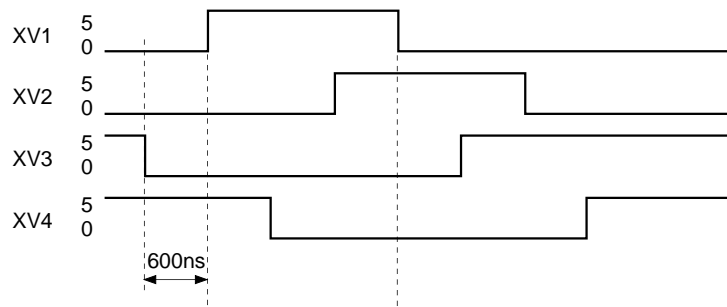

Output Waveform

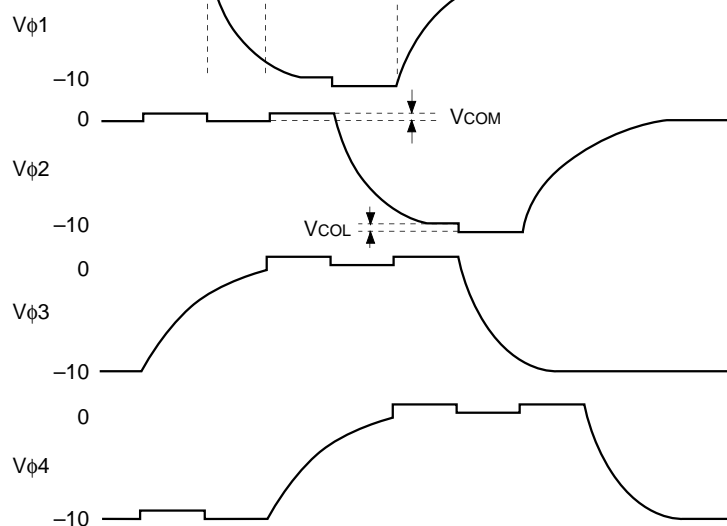

**Switching Waveform
Input Waveform**

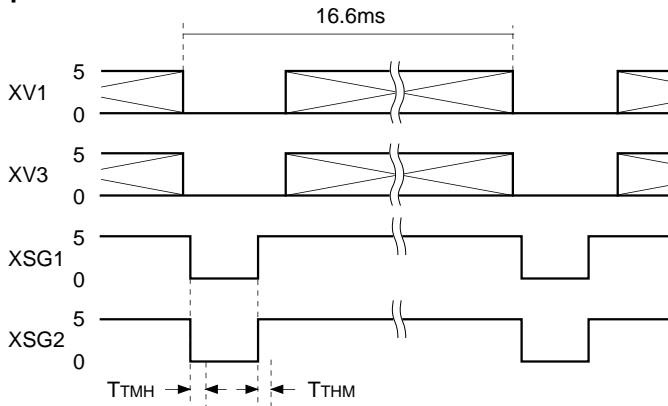

Output Waveform

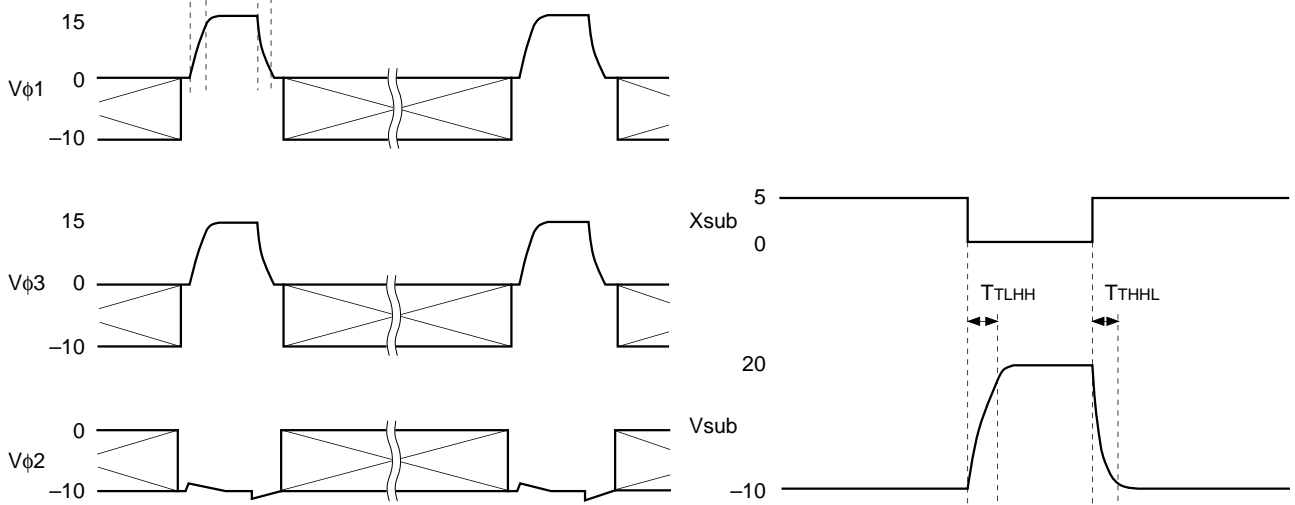

Test Circuit

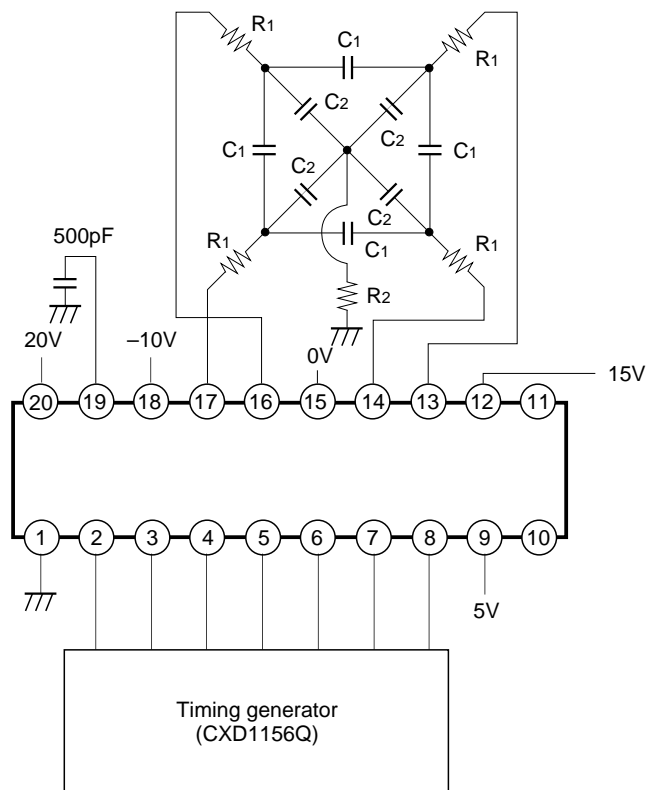

- R1; 27Ω
- R2; 5Ω
- C1; 1500pF
- C2; 3300pF

Application Circuit

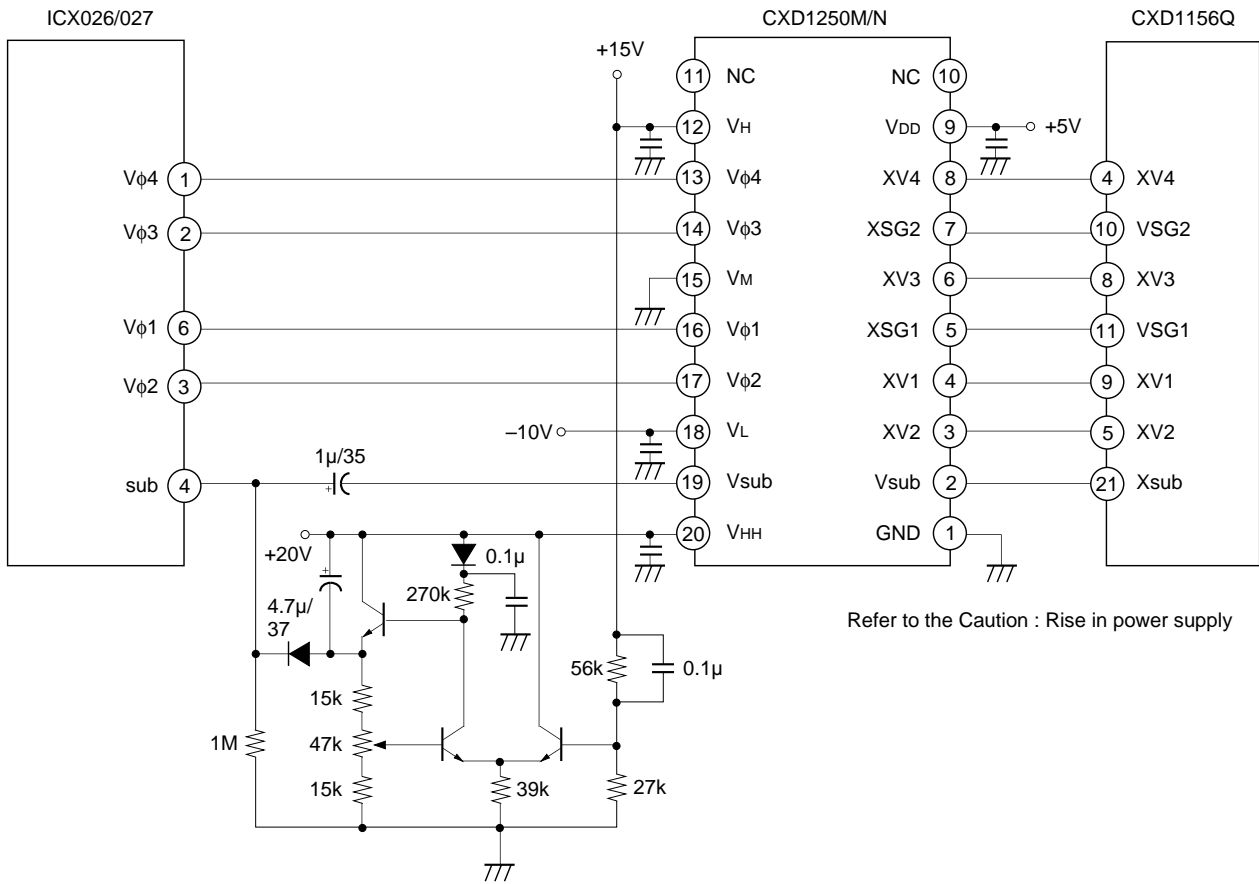

Refer to the Caution : Rise in power supply

Note:
The capacitor more than 0.1μF should be connected between the ground and each pin of VDD, VH, VHH and VL .

Caution : Rise in Power Supply

When the substrate driver is in use, be careful not to let the CCD imagesensors Sub (pin 4) turn into negative voltage.

To this end, raise VL and VHH at the application circuit under the following conditions.

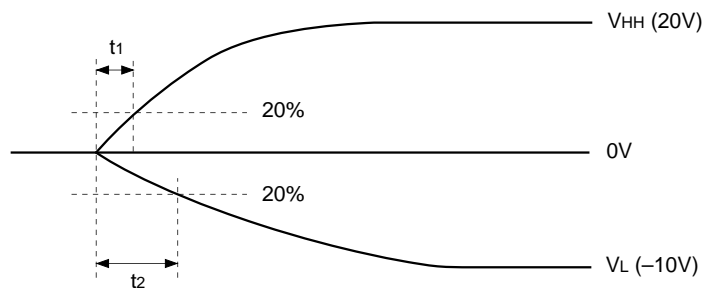

$$t_2 \geq t_1 \geq 10\text{msec}$$

Package Outline

Unit: mm

CXD1250M

20PIN SOP (PLASTIC) 300mil

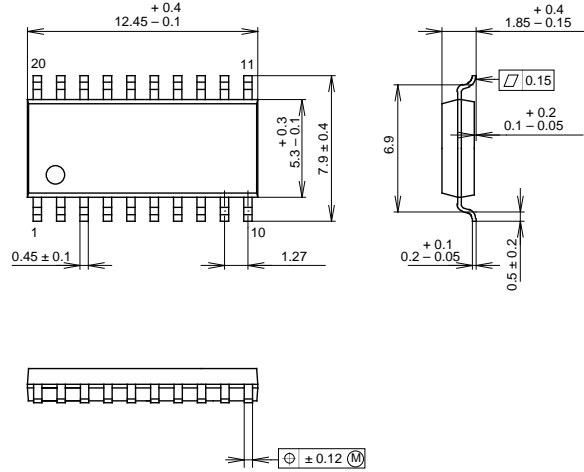

PACKAGE STRUCTURE

SONY CODE	SOP-20P-L01
EIAJ CODE	+SOP020-P-0300-A
JEDEC CODE	

PACKAGE MATERIAL	EPOXY / PHENOL RESIN
LEAD TREATMENT	SOLDER PLATING
LEAD MATERIAL	COPPER ALLOY
PACKAGE WEIGHT	0.3g

CXD1250N

20PIN SSOP (PLASTIC)

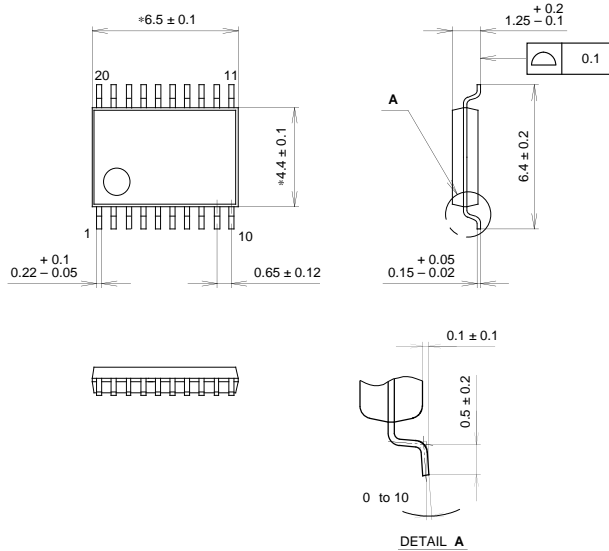

NOTE: Dimension "*" does not include mold protrusion.

PACKAGE STRUCTURE

SONY CODE	SSOP-20P-L01
EIAJ CODE	SSOP020-P-0044
JEDEC CODE	

PACKAGE MATERIAL	EPOXY RESIN
LEAD TREATMENT	SOLDER / PALLADIUM PLATING
LEAD MATERIAL	COPPER / 42 ALLOY
PACKAGE WEIGHT	0.1g