

System power supply for car stereos

BA3918

The BA3918 is a single-chip power supply IC for use in car audio systems. One 5.6V output for a microcontroller, three 8.7V outputs, and two outputs interlocked by BACKUP and ACC systems are built in.

●Applications

Car audio systems

●Features

- 1) All outputs except AMP and ANT use a PNP transistor with a low saturation voltage.
- 2) Output current limit circuit prevents damage to the IC due to short-circuiting.
- 3) Overvoltage protection circuit provides protection against surges from the Acc or BACKUP input.
- 4) Compact 12-pin POWER package allows large power dissipation.
- 5) Thermal protection circuit prevents heat damage to the IC.

●Block diagram

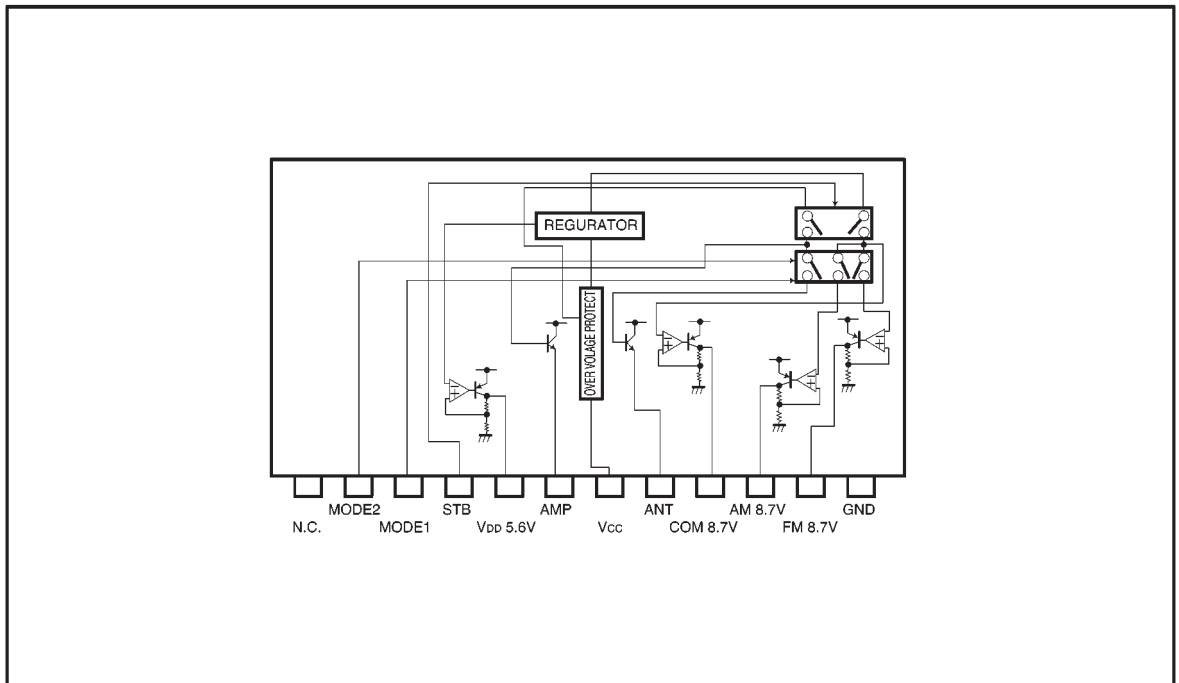

● Absolute maximum ratings (Ta = 25°C)

Parameter	Symbol	Limits	Unit
Power supply voltage	V _{CC}	24	V
Power dissipation	P _d	3000	mW
Operating temperature	T _{opr}	-30~+85	°C
Storage temperature	T _{stg}	-55~+150	°C
Peak applied voltage	V _{CC} PEAK	50*1	V

*1 Tr ≥ 1 msec, applied time is less than 200 msec.

● Recommended operating conditions (Ta = 25°C)

Parameter	Symbol	Min.	Typ.	Max.	Unit
Recommended power supply voltage	V _{CC}	10	13.2	16	V
Operable voltage *	V _{CC}	6.3	13.2	24	V

* Not intended to ensure electrical characteristics (in particular, during a voltage drop).

● Pin descriptions

Pin No.	Pin name	Function
1	N. C.	Not used
2	MODE2 SW	AM and ANT outputs are turned ON when this pin is 5 V.
3	MODE1 SW	AM and FM outputs are switched when this pin is 5 V.
4	STAND BY	Only V _{DD} is output during the 0 V standby state; COM and AM outputs are turned ON when this pin is 5 V.
5	V _{DD} output	5.6 V power supply with a maximum output of 100 mA for a microcontroller; output is always available if BACKUP power supply is connected.
6	AMP output	Power supply to activate a remote amplifier; a voltage of about 1 V (typical) lower than the V _{CC} voltage is provided with a maximum output of 500 mA.
7	V _{CC}	Connected to car BACKUP and ACC power supplies.
8	ANT output	Power supply to drive an antenna; a voltage of about 1 V (typical) lower than the V _{CC} voltage is provided with a maximum output of 500 mA.
9	COM output	8.7 V power supply with a maximum output of 150 mA; this can be used as a system common power supply (such as tone, volume, and balance control) or a power supply for cassette player equalizers and electronic tuning variable capacitors.
10	AM output	8.7 V power supply with a maximum output of 150 mA for AM receiver
11	FM output	8.7 V power supply with a maximum output of 250 mA for FM receiver
12	GND	Connected to the IC substrate.

● Input / output circuits

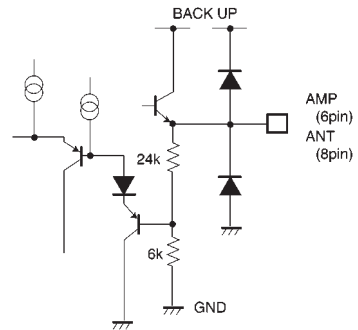
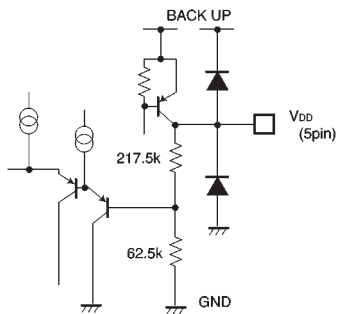
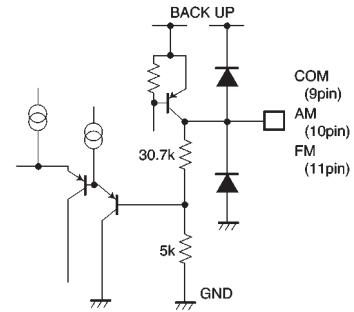
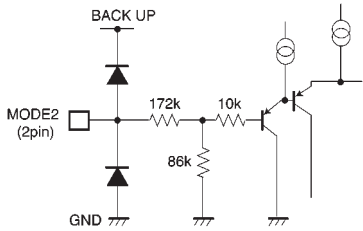
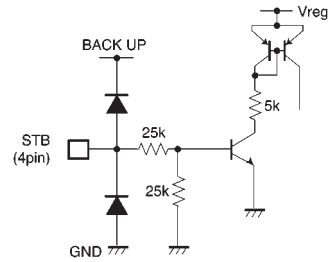
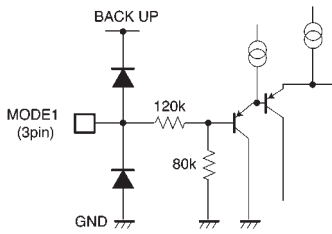

●Electrical characteristics (unless otherwise noted, Ta = 25°C and V_{CC} = 13.2V)

Parameter	Symbol	Min.	Typ.	Max.	Unit	Conditions
Standby supply current	I _{ST}	—	0.55	0.80	mA	STAND BY pin=0 V
Output voltage (V _{DD}) 1	V _{O1}	5.30	5.60	5.90	V	I _{O1} =80mA
Voltage regulation	ΔV _{O11}	—	5	15	mV	V _{CC} =10~16V I _{O1} =80mA
Load regulation	ΔV _{O12}	—	60	170	mV	I _{O1} =0~80mA
Minimum I / O voltage differential	ΔV _{O13}	—	0.3	0.7	V	I _{O1} =80mA
Output current capacity	I _{O1}	100	200	—	mA	V _{O1} ≥5.3V
Ripple rejection ratio	R.R1	50	60	—	dB	f=100Hz V _{RR} =-10dBV
Output voltage (COM) 2	V _{O2}	8.25	8.70	9.15	V	I _{O2} =120mA
Voltage regulation	ΔV _{O21}	—	10	30	mV	V _{CC} =10~16V I _{O2} =120mA
Load regulation	ΔV _{O22}	—	90	210	mV	I _{O2} =0~120mA
Minimum I / O voltage differential	ΔV _{O23}	—	0.4	0.7	V	I _{O2} =120mA
Output current capacity	I _{O2}	150	300	—	mA	V _{O2} ≥8.25V
Ripple rejection ratio	R.R2	50	60	—	dB	f=100Hz V _{RR} =-10dBV
I / O voltage differential (AMP) 3	ΔV _{O31}	—	1	1.5	V	I _{O3} =400mA
Load regulation	ΔV _{O32}	—	350	600	mV	I _{O3} =0~400mA
Output current capacity	I _{O3}	500	900	—	mA	V _{O3} ≥11.7V
I / O voltage differential (ANT) 4	ΔV _{O41}	—	1	1.5	V	I _{O4} =400mA
Load regulation	ΔV _{O42}	—	350	600	mV	I _{O4} =0~400mA
Output current capacity	I _{O4}	500	900	—	mA	V _{O4} ≥11.7V
Output voltage (AM) 5	V _{O5}	8.25	8.70	9.15	V	I _{O5} =120mA
Voltage regulation	ΔV _{O51}	—	10	30	mV	V _{CC} =10~16V I _{O5} =120mA
Load regulation	ΔV _{O52}	—	90	210	mV	I _{O5} =0~120mA
Minimum I / O voltage differential	ΔV _{O53}	—	0.4	0.7	V	I _{O5} =120mA
Output current capacity	I _{O5}	150	300	—	mA	V _{O5} ≥8.25V
Ripple rejection ratio	R.R5	50	60	—	dB	f=100Hz V _{RR} =-10dBV
Output voltage (FM) 6	V _{O6}	8.25	8.70	9.15	V	I _{O6} =200mA
Voltage regulation	ΔV _{O61}	—	20	60	mV	V _{CC} =10~16V I _{O6} =200mA
Load regulation	ΔV _{O62}	—	90	210	mV	I _{O6} =0~200mA
Minimum I / O voltage differential	ΔV _{O63}	—	0.4	0.7	V	I _{O6} =200mA
Output current capacity	I _{O6}	250	500	—	mA	V _{O6} ≥8.25V
Ripple rejection ratio	R.R6	45	55	—	dB	f=100Hz V _{RR} =-10dBV

Parameter	Symbol	Min.	Typ.	Max.	Unit	Conditions
〈Input (STAND BY)〉						
Standby level	V_{TH1-1}	—	—	1.1	V	
Active level	V_{TH1-2}	1.7	—	—	V	
Input high level current	I_{IN1}	100	175	250	μA	$V_{TH1}=5V$
〈Input (MODE 2 SW)〉						
Standby level	V_{TH2-1}	—	—	1.6	V	
Active level	V_{TH2-2}	2.4	—	—	V	
Input high level current	I_{IN2}	13	25	37	μA	$V_{TH2}=5V$
〈Input (MODE 1 SW)〉						
Level when AM ON	V_{TH3-1}	—	—	1.1	V	
Level when FM ON	V_{TH3-2}	2.7	—	—	V	
Input high level current	I_{IN3}	13	25	37	μA	$V_{TH3}=5V$

©Not designed for radiation resistance.

*Set output current to less than the minimum value of output current capacity.

● Input / output timing chart

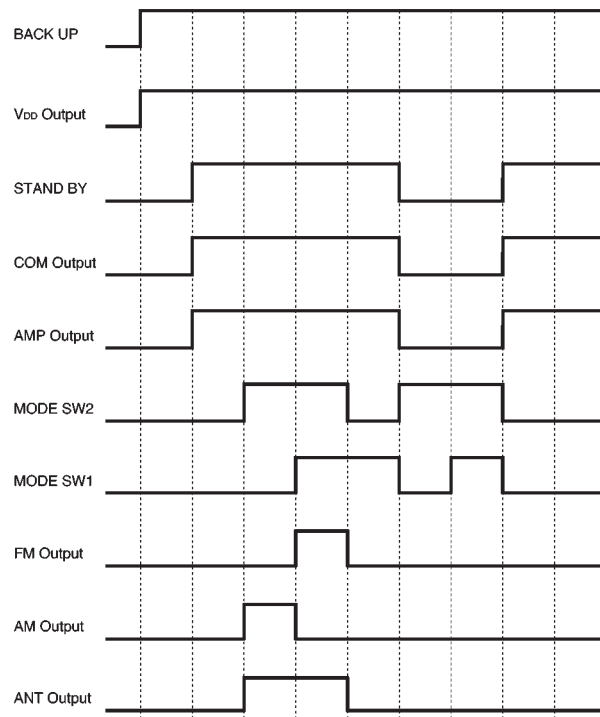

Fig.1

● Estimate of allowable power dissipation

Except under transitional conditions, the power dissipation of this IC is 3W per unit at 25°C.

See Fig. 4 for thermal derating characteristics, including some cases where heat sinks are used.

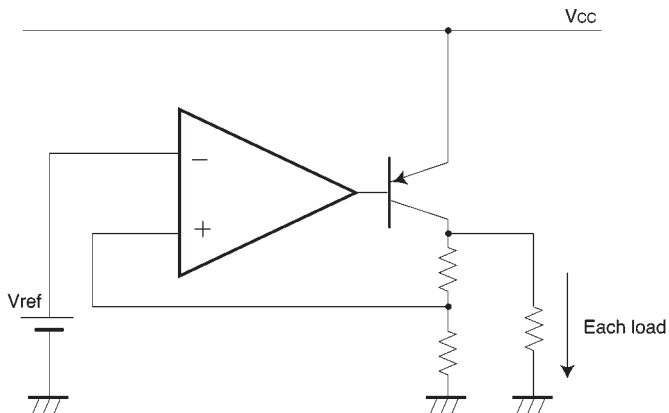

Fig.2

A = maximum voltage for V_{CC}
 I_1 = maximum output current for V_{DD}
 I_2 = maximum output current for COM
 I_3 = maximum output current for AMP
 I_4 = maximum output current for ANT
 I_5 = maximum output current for AM
 I_6 = maximum output current for FM

- Power consumed by V_{DD} 5.6V
- Power consumed by COM 8.7V
- Power consumed by AMP
- Power consumed by ANT
- Power consumed by AM 8.7V
- Power consumed by FM 8.7V
- Power consumed internally by each circuit

$$P_1 = (A - 5.6V) \times I_1 + (I_1 / 20 + I_1 / 10) \times A$$

$$P_2 = (A - 8.7V) \times I_2 + (I_2 / 30 + I_2 / 10) \times A$$

$$P_3 = 1V \times I_3 + (22mA) \times A$$

$$P_4 = 1V \times I_4 + (22mA) \times A$$

$$P_5 = (A - 8.7V) \times I_5 + (I_5 / 30 + I_5 / 10) \times A$$

$$P_6 = (A - 8.7V) \times I_6 + (I_6 / 50 + I_6 / 10) \times A$$

$$P_7 = V_{CC} \times \text{circuit current (about 5mA)}$$

$$P_{Max.} = P_1 + P_2 + P_3 + P_4 + (P_5 \text{ or } P_6, \text{ whichever is greater}) + P_7$$

● Application example

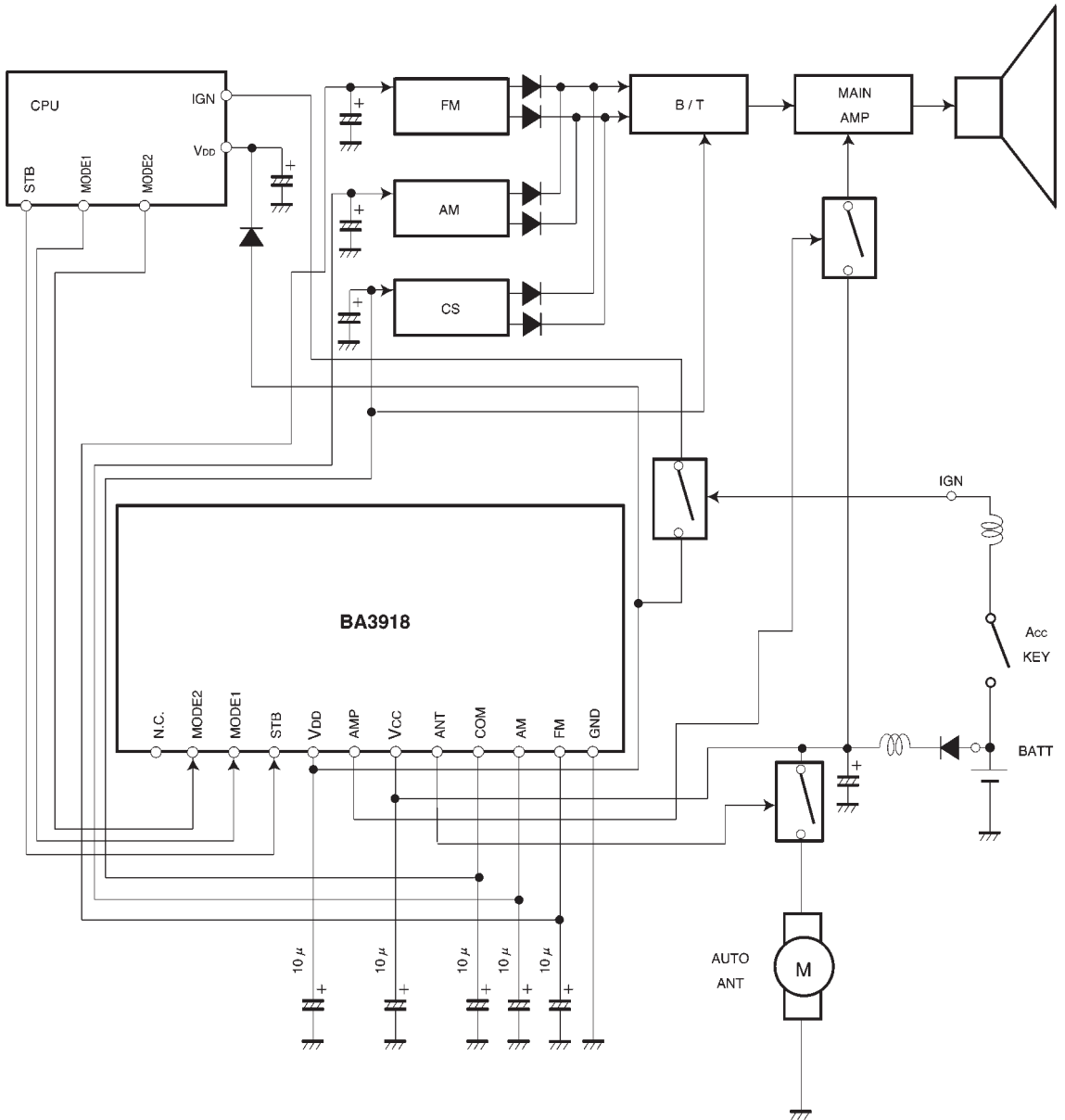

Fig.3

● Operation notes

(1) Example of application

The application circuit of Fig. 3 is recommended for use. Make sure to confirm the adequacy of parts characteristics. When using the circuit with changes to external circuit constants, make sure to leave sufficient margins in consideration of fluctuations in the IC and external components including static and transitional characteristics. Note that ROHM has not carried out extensive survey regarding the patent right of this application.

(2) Operating power supply voltage

When operating within the proper ranges of power supply voltage and ambient temperature, most circuit functions are guaranteed. Although the rated values of electrical characteristics cannot be absolutely guaranteed, characteristic values do not change drastically within the proper ranges.

(3) Power dissipation (Pd)

Refer to the power dissipation curves (Fig. 4) and the rough estimation of IC power dissipation given on a separate page. Make sure your design allows a maximum power within the operating temperature range.

(4) Overvoltage protection circuit

The overvoltage protection circuit turns OFF all outputs when the potential difference between V_{CC} (pin 7) and GND (pin 12) is more than about 26V at normal temperature. Make sure to use the IC within this voltage limit.

(5) Preventing oscillation at each output

To stop output oscillation, make sure to connect a capacitor having a capacitance of 10 μ F or greater between GND and each of the V_{DD} (pin 5), COM (pin 9), AM (pin 10), and FM (pin 11) output pins. We recommend using a tantalum electrolytic capacitor whose capacitance is unsusceptible to temperature.

(6) Overcurrent protection circuit

An overcurrent protection circuit is installed on the V_{DD} (pin 5), AMP (pin 6), ANT (pin 8), COM (pin 9), AM (pin 10), and FM (pin 11) outputs, based on the respective output current. This prevents IC destruction due to overcurrent, by limiting the current with a curve shape of "7" in the voltage-current graph. The IC is designed with margins so that current flow will be restricted and latching will be prevented even if a large current suddenly flows through a large capacitor. The circuit should be carefully set because output current is further restricted when output voltage is less than 1V_F (considered as short mode).

(7) Thermal protection circuit

A built-in thermal protection circuit prevents thermal damage to the IC. All outputs except V_{DD} are switched OFF when the circuit operates, and revert to the original state when temperature drops to a certain level.

(8) Grounding

Each ground trace in the application circuit of Fig. 3 must be adequately short from GND (pin 12). Make sure to arrange the ground traces in a pattern that prevents mutual interference.

(9) Although the quality of this IC is rigorously controlled, the IC may be destroyed when the supply voltage or the operating temperature exceeds their absolute maximum ratings. Because short mode or open mode cannot be specified when the IC is destroyed, be sure to take physical safety measures, such as fusing, if any of the absolute maximum ratings might be exceeded.

(10) We recommend installing a bypass line in your application if there is a mode where potential difference between each output and input (V_{CC}) or GND is reversed from the normal state.

● Thermal derating characteristic curve

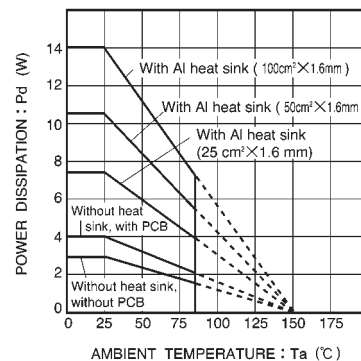

Fig.4

●Electrical characteristic curves

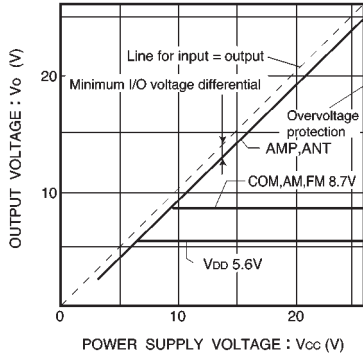

Fig.5 Output voltage vs. power supply voltage

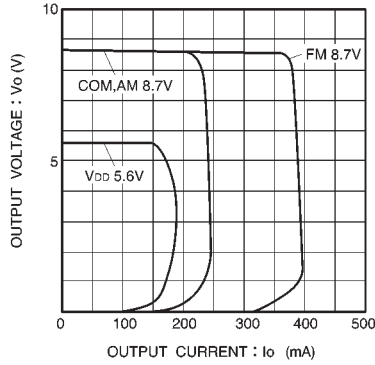

Fig.6 Output voltage vs. current

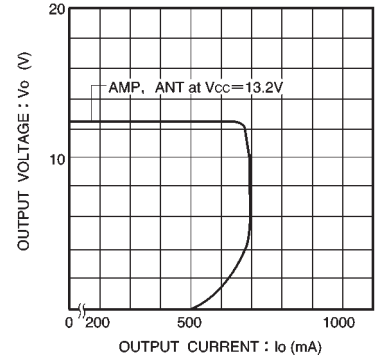

Fig.7 Output voltage vs. current

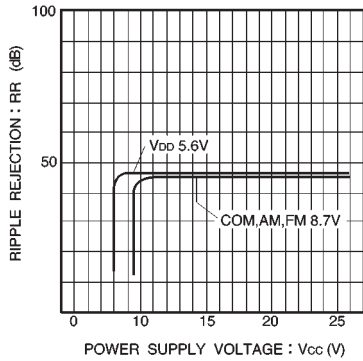

Fig.8 Ripple rejection vs. power supply voltage

●External dimensions (Units: mm)

