



AY-5-1200A
AY-5-1202A

AY-5-1203A
AY-5-1204A

4 Digit Clock Circuits

FEATURES

- Hours and minutes display.
- 12/24 hour operation.
- 50/60Hz operation.
- High voltage direct Fluorescent drive Outputs.
- Flashing seconds output (option).
- BCD output (option).
- Leading Zero Blanking (option).
- Power-On Reset to zero.
(Counting does not start until time is set.)
- Options:

	7 Seg	BCD	Zero Blank	Flashing Sec
AY-5-1200A	Yes	No	Yes	No
AY-5-1202A	Yes	No	Yes	Yes
AY-5-1203A	No	Yes	No	Yes
AY-5-1204A	Yes	No	No	Yes

DESCRIPTION

The AY-5-1200A Series are P-Channel MOS integrated circuits, containing all the logic necessary to make a 4 digit, 12 or 24 hour clock, operating from 50 or 60Hz. High voltage output stages capable of driving fluorescent displays are provided.

PIN CONFIGURATION

24 LEAD DUAL IN LINE
AY-5-1200A/AY-5-1202A/AY-5-1204A

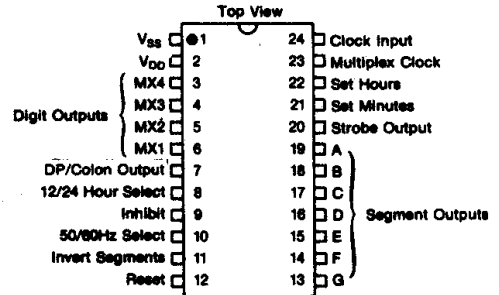

AY-5-1203A

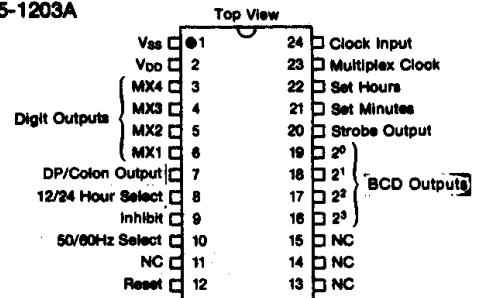

BLOCK DIAGRAM

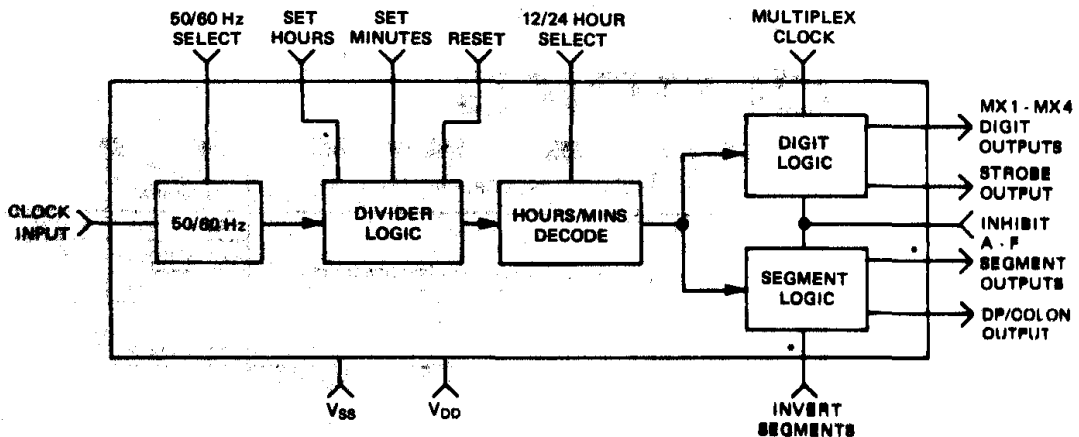

* Not included in the AY-5-1203A.
Four BCD outputs are provided in place of the seven segment outputs

Name	Function
Segment Outputs A—F	In 7 segment mode the digits are multiplexed on to these pins. These outputs are at logic '0' to display (positive) and will drive Fluorescent displays directly. In BCD mode outputs A to D are used, the code for 0 being 0000.
DP/Colon Output	This is a high voltage output intended to drive a decimal point or colon. It is enabled during the MX3 time slot and can flash once per second if required.
Multiplex Outputs MX1—MX4	These outputs select the display digits sequentially, they will drive Fluorescent displays directly. Five multiplex time slots are generated the fifth one being blank. Minutes are output in MX1 time, 10's of hours in MX4 time.
Reset Input	When taken to logic '0' the clock is reset to zero.
Set Minutes Input	When taken to logic '0' the minutes counter is advanced at the rate of 2 min. per sec. and the hours counter at the rate of 2 hours per minute.
Set Hours Input	When taken to logic '0' the hours counter is advanced at the rate of 2 hours per second.
50/60Hz Select Input	When taken to logic '0', 60Hz operation will result.
12/24 Hours Select Input	When taken to logic '0', 12 hour operation will result.
Invert Segments Input	When taken to logic '0' the segment outputs will be inverted.
Multiplex Oscillator	An external capacitor is used to select the multiplex frequency. If required the pin can be driven by an external oscillator.
50/60Hz Input	The master clock is input to the pin. Hysteresis is provided so that the input waveform is not critical.
V _{ss}	Positive Supply.
V _{DD}	Negative Supply.
Inhibit Input	When taken to logic '0' all outputs are switched OFF.
Strobe Output	This is a short pulse occurring during the middle of each multiplex period.

ELECTRICAL CHARACTERISTICS

Maximum Ratings*

Voltage on any pin with respect to V _{ss} pin (except Segment and Multiplex outputs)	+0.3 to -35V
Operating Temperature Range	0°C to +70°C
Storage Temperature Range	-65°C to +150°C
Power Dissipation at +70°C Ambient—Total	500mW
Per Output	50mW

*Exceeding these ratings could cause permanent damage. Functional operation of these devices at these conditions is not implied—operating ranges are specified below.

Standard Conditions (unless otherwise noted)

V_{ss} = -0V
V_{DD} = -17V ± 10% (AY-5-1200A/1202A/1204A)
V_{DD} = -11.4V to -19V (AY-5-1203A)
Operating Temperature (T_A) = 0°C to +70°C

NOTE:

In the chart below, numbers in () refer only to the AY-5-1203A.

Characteristic	Min.	Typ**	Max	Units	Conditions
Clock input frequency	DC	50/60	—	Hz	
Clock input logic '0'	+0.5	—	-2(-1)	Volts	Note 1
Clock input logic '1'	-8	—	V _{DD}	Volts	
Multiplex clock frequency	DC	—	50	kHz	Note 2
Control inputs logic '0'	+0.3	—	-1.5(-1)	Volts	
Control inputs, current logic '0'	—	100	—	μA	Note 3
Control inputs logic '1'	-8	—	-V _{DD}	Volts	
Segment Outputs					
ON current	2(1.3)	—	—	mA	V _{OUT} = -2V
OFF leakage	—	—	5(10)	μA	V _{OUT} = -25V(-19V)
			10	μA	V _{OUT} = -35V
Multiplex Outputs					
ON current	5(3.3)	—	—	mA	V _{OUT} = -2V
OFF leakage	—	—	5(10)	μA	V _{OUT} = -25V(-19V)
			10	μA	V _{OUT} = -35V
Supply Current	—	8.5(6.5)	14	mA	

**Typical values are at +25°C and nominal voltages.

NOTES:

- The clock input pin may be taken positive with respect to V_{ss} provided that the current is limited to 100μA. The input will behave like a forward biased silicon diode in this condition.
- The frequency is determined by an external capacitor.
- These inputs have a 170Kohm pull up resistor to V_{DD}.